

12 oz.

TWO PIECE AL. CAN
202/355ML PRODUCT SPECIFICATION

Document No:

Edition: A1

Revision Date: 2020-7-15

Page No: 1/2

TWO PIECE AL CAN 202/211x413, 355ml FOR CARBONATED SOFT DRINK/RETORT WITH LIQUID NITROGEN/BEER

SCOPE :

THIS STANDARD IS APPLIED TO TWO PIECE AL. CAN BODY 202/211x413
IT COVERS THE CAN MATERIAL SPECIFICATION AND THE FACTORY FINISHED
CAN DIMENSIONAL STANDARD.

PLATE MATERIAL :

-ALUMINUM.
-ALLOY AND TEMPER: 3104 H19

STRENGTH :

-AXIAL LOAD : ≥ 0.8 KN
-BUCKLE : ≥ 610 KPA

COATINGS :

-INSIDE : MODIFIED EPOXY
-OUTSIDE : DECORATED + CLEAR VARNISH + BRC

ENAMEL RATE

-INTERNAL COATING COVERAGE : BEER ≤ 75 MA, AVERAGE ≤ 35 MA
SOFT DRINK ≤ 25 MA, AVERAGE ≤ 5 MA
RETORT ≤ 30 MA, AVERAGE ≤ 8 MA

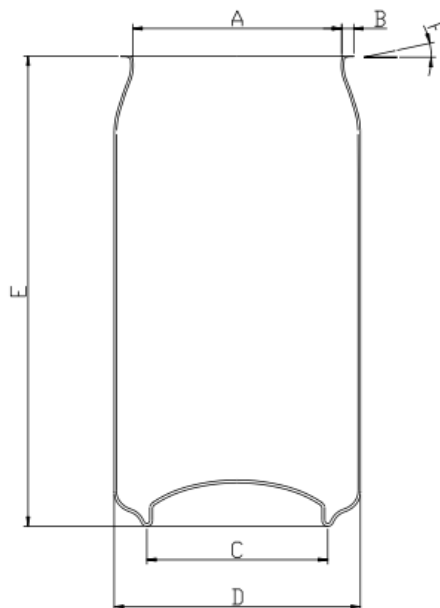

DIMENSION KEY		
A	PLUG DIAMETER	52.40±0.25mm
B	FLANGE WIDTH	2.10±0.25mm
C	BASE DIAMETER	48.00mm REF
D	BODY OUTSIDE DIAMETER	66.10mm REF
E	FINISHED CAN HEIGHT	122.22±0.38mm
F	FLANGE ANGLE	0° -12°
G	FULL CAPACITY	382.38±1.8ml

12 oz.

TWO PIECE AL. CAN
202/355ML PRODUCT SPECIFICATION

Document No:

Edition: A1

Revision Date: 2020-7-15

Page No: 2/2

PACKING SPECIFICATION :

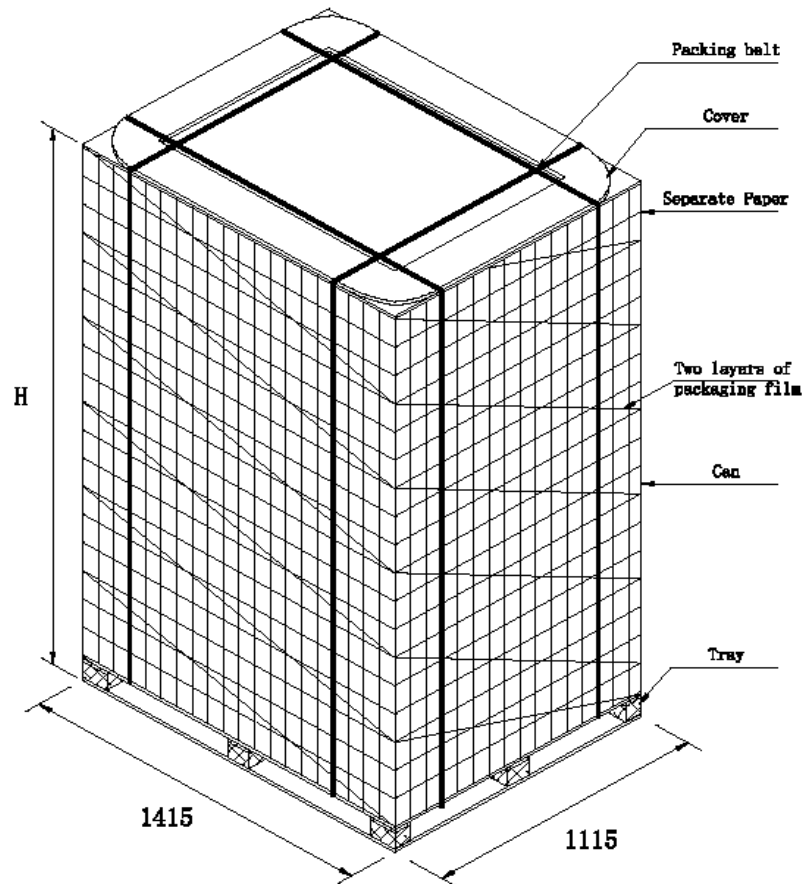

Package type	Package height (mm)	QTY/Per Tray (pcs)	QTY/Per Layer
17	2215 ± 15	6613	389
18	2338 ± 15	7002	
19	2461 ± 15	7391	
20	2583 ± 15	7780	
Prepared by:		Checked by:	Approved by: