

**EOE**  
**202SOT Large Opening Product**  
**Specification**

Document No:  FAE-050

Revision: A1

Revision Date: 2018-12-05

Page No: 1/3

**SCOPE**

Aluminium has a steam easy EOE applies beer, carbonated beverages and soft material nitrogen containers

**1. MATERIAL SPECIFICATION**

1.1 End Stock Gauge:  $0.220 \pm 0.005\text{mm}$

1.2 Lining Compound Type: Water Based Compound

**2. DIMENSIONAL STANDARD**

| DESCRIPTION                |   | SPECIFICATION                                  |
|----------------------------|---|--|
| Outside Curl Diameter (mm) | A | $59.44 \pm 0.25$                               |
| Curl Height (mm)           | B | $2.03 \pm 0.15$                                |
| Countersink Depth (mm)     | C | $6.86 \pm 0.13$                                |
| Curl Opening (mm)          | D | 2.72 (MIN)                                     |
| Ends Per 2 inch (pcs)      |   | $26 \pm 2$                                     |
| Compound Weight (mg)       |   | $25 \pm 5$                                     |
| Pop (N)                    |   | $\leq 31$ , Avg $\leq 20$                      |
| Pull (N)                   |   | $\leq 45$ , Avg $\leq 36$                      |
| Buckle (kPa)               |   | $\geq 610$                                     |
| ERV                        |   | Max $\leq 25\text{mA}$ , Avg $\leq 5\text{mA}$ |

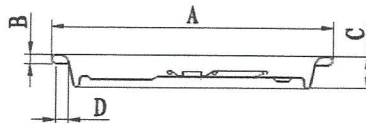
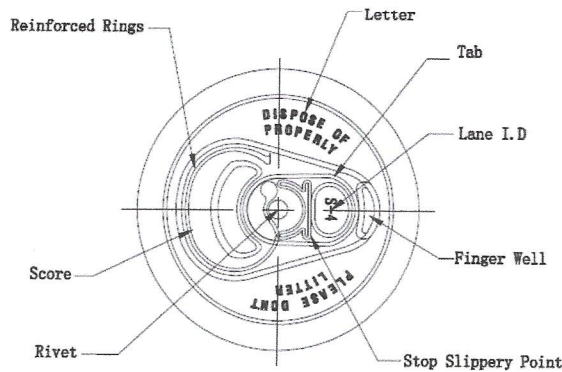

|  |  |
|--|--|
| <p><b>EOE</b><br/> <b>202SOT Large Opening Product</b><br/> <b>Specification</b></p> | Document No: <span style="border: 1px solid black; padding: 2px;"> </span> FAE-050 |
|  | Revision: A1   |
|  | Revision Date: 2018-12-05  |
|  | Page No: 2/3   |

**3. PACKING SPECIFICATION**

- 3.1. Number Of Packages: 19Layer\*17Article\*500Pcs/Article =161500Pcs
- 3.2. Packing Volume: 1100mm (Long) \*1000mm (Wide) \*1150mm (High)
- 3.3. Packing Way:

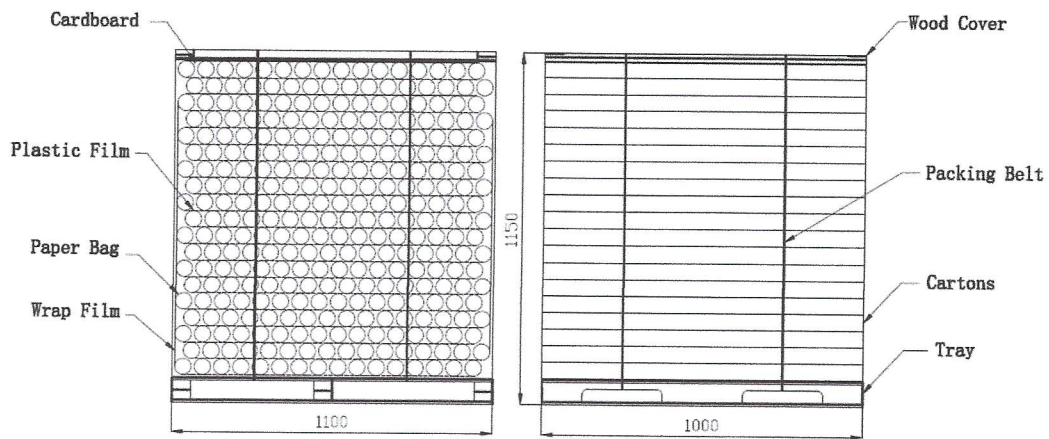

**4. DOUBLE SEAMING TOOLING**

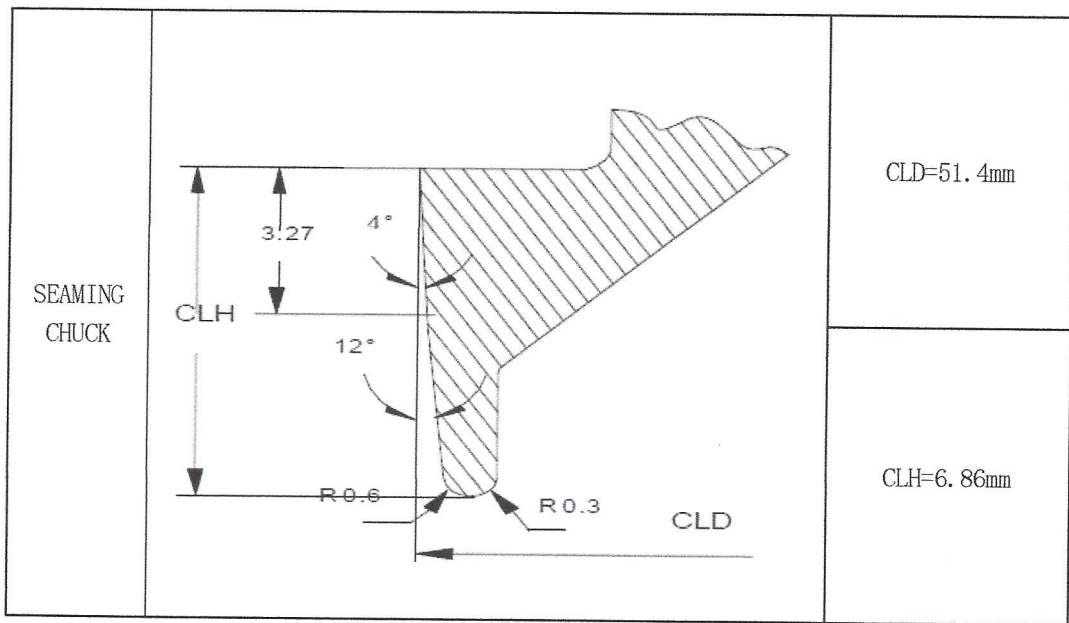

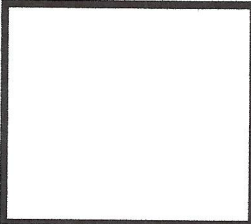

**EOE**  
**202SOT Large Opening Product**  
**Specification**

Document No:  FAE-050

Revision: A1

Revision Date: 2018-12-05

Page No: 3/3

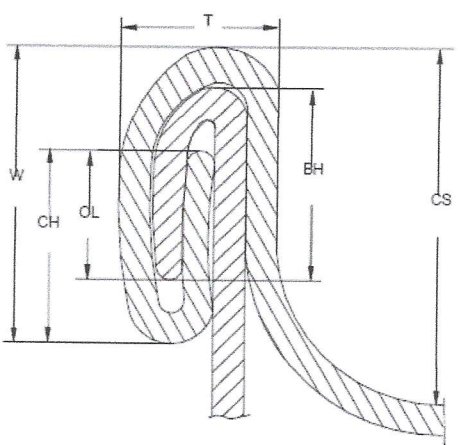
|  | DESCRIPTION           |    | SPECIFICATION<br>(mm) |
|--|-----------------------|----|-----------------------|
|  | 1st OP Seam Thickness | Tc |                       |
| 2nd OP Seam Thickness  | T                     |    | $1.15 \pm 0.05$       |
| Seam Width   | W                     |    | $2.60 \pm 0.2$        |
| Counter Sink   | CS                    |    | $6.86 \pm 0.13$       |
| Body Hook  | BH                    |    | $1.60 \pm 0.2$        |
| Cover Hook   | CH                    |    | $1.60 \pm 0.2$        |
| Over Lay   | OL                    |    | 0.76Min               |

Approval by:

Audit by:

Compile: